

AST A450C PL NV TL 55 Ratio pyrometer for industrial application

Overview

Digital pyrometers with RS-485 interface



Special features

- For temperature measurements between 500 °C and 3000 °C
- Temperature linear output 0/4 to 20 mA, switchable
- Display, keys and RS-485 interface
- Different fixed optics or vario optics with motor focus
- Laser aiming light, integrated color video camera or through-lens sighting
- Very short response time 5 ms

Description and application

The digital AST A450C PL NV TL 55 ratio pyrometers are specially designed for industrial use. They are suitable for temperature measurements from 500 °C on a variety of surfaces, such as metals, graphite or ceramics. The AST A450C measures the infrared radiation in two neighboring wavelength ranges and determines the temperature value.

With different fixed optics, target sizes starting from 0.8 mm are available. As an option a vario optics with motorized focus is possible. For example, if the devices are installed in hard-to-reach places, the user can conveniently change or adjust the focus. Ratio correction and motor focus can be set directly at the device using buttons and display. All other parameters are adjusted via interface and software, for example AST NET1.

Even in harsh environments, the compact and robust IP 65 stainless steel housing of the pyrometer can withstand. With a minimum response time of only 5 ms (t_{95}), the devices also realize fast measuring tasks.

Thanks to the temperature linear standard output signal of 0/4 to 20 mA, the pyrometers can be easily integrated into existing measurement and control systems. The pyrometer has a galvanically isolated RS-485 interface. The device is thus bus capable and uses the Modbus RTU protocol. The connection to local networks can be supported by an Ethernet interface box.

The integrated red laser aiming light helps to precisely align the pyrometer with the target. If the objects are very hot, it is recommended to use an integrated color video camera instead of the laser as a aiming variant (AST A450C PL NV TL 55). Thus, a glare-free alignment is easily possible. The integrated video camera also facilitates installation in difficult local conditions, where the pyrometer is difficult to reach or the measurement object is not visible. Optionally, a through-lens sighting is available.

Typical application areas:

- Steel and metal industry
- Furnace industry
- Soldering applications
- Ceramic industry

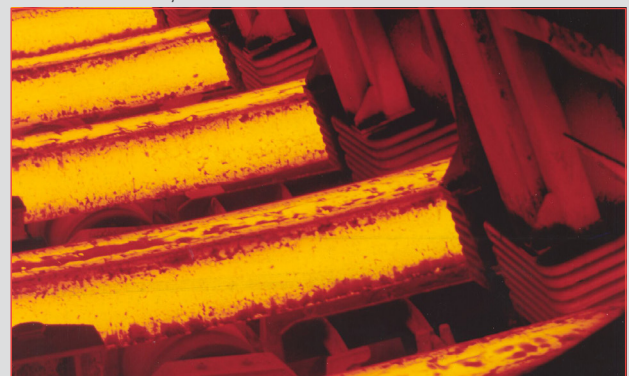

AST A450C PL NV TL 55

Ratio pyrometer for industrial application

Technical data

AST A450C PL NV TL 55										
Type	AST A450C PL NV TL 55									
Measuring temperature range	500 °C to 1200 °C		600 °C to 1400 °C		700 °C to 1800 °C		800 °C to 2500 °C		900 °C to 3000 °C	
Optics	different fixed optics (type 250, 650, 2000, 4000) or optionally vario optics with motor focus									
Part number	Through-lens sighting		Through-lens sighting		Through-lens sighting		Through-lens sighting		Through-lens sighting	
	Video	Laser	Video	Laser	Laser	Video	Laser	Video	Laser	Video
250	5552072201		5552072202		5552072203		5552072204		5552072205	
	5552062201	5552082201	5552062202	5552082202	5552062203	5552082203	5552062204	5552082204	5552062205	5552082205
650	5552073201		5552073202		5552073203		5552073204		5552073205	
	5552063201	5552083201	5552063202	5552083202	5552063203	5552083203	5552063204	5552083204	5552063205	5552083205
2000			5552076202		5552076203		5552076204		5552076205	
	5552066201	5552086201	5552066202	5552086202	5552066203	5552086203	5552066204	5552086204	5552066205	5552086205
4000	5552077201		5552077202		5552077203		5552077204		5552077205	
	5552067201	5552087201	5552067202	5552087202	5552067203	5552087203	5552067204	5552087204	5552067205	5552087205
Vario optics	5552021201		5552021202		5552021203		5552021204		5552021205	
	5552011201	5552031201	5552011202	5552031202	5552011203	5552031203	5552011204	5552031204	5552011205	5552031205
Sub temperature range of analog output	adjustable within measuring temperature range, minimum span 50 °C									
Spectral range	0.7 µm to 1.1 µm									
Ratio correction K	0.800 to 1.200									
Emissivity ε	0.050 to 1.000 (1-channel mode)									
Response time (t ₉₅)	5 ms ³ , adjustable up to 100 s									
Measurement uncertainty ₁	0.5 % of measured value in °C +1 K									
Reproducibility ₁	0.2 % of measured value in °C + 0.5 K									
NETD ₂	0.1 K ₁									
Transmittance	50 % to 100 %									
Analog output	0/4 mA to 20 mA, temperature linear, maximum burden 500 Ω (galvanically isolated)									
Interface	RS-485 (galvanically isolated), half duplex, max. 115 kBd, Modbus RTU protocol									
Aiming	A450C PL NV 55: laser aiming light (630 ... 680 nm, class II, < 1 mW) or through-lens sighting ₄ A450C TL55: video camera, composite video, galvanically isolated (PAL (B), 50 Hz or optional NTSC (M), 60 Hz)									
Switching output/ Switching threshold	1 opto relay, R min. 48 Ω (galvanically isolated)/adjustable within measuring temperature range ^{Burden}									
Operating and display elements	Two push-buttons for „Parameter menu“, „Enter“, „Up“ and „Down“, OLED with standard display of temperature and ratio correction, pilot light button (option)									
Parameters	– adjustable via interface and software: ratio correction, emissivity, transmittance, response time, memory settings, sub temperature range of measuring output, switching threshold of switching output, motor focus – adjustable additionally on the device with push-buttons and display: ratio correction, motor focus									
Power supply	24 V DC ± 25 %, residual ripple 500 mV									
Power consumption	max. 1.5 W (without burden on switching output)									
Operating temperature	0 °C to 70 °C									
Storage temperature	–20 °C to 70 °C									
Weight	approx. 600 g									
Housing	stainless steel housing with plug connector, length approx. 105 mm (without through-lens sighting), diameter 50 mm									
IP code	IP65 according to DIN EN 60529 und DIN 40050									
Test regulations	EN 55 011:1998, limit class A									
CE symbol	according to EU regulations									
Scope of delivery	AST A450C PL NV TL 55, user manual, inspection sheet, software AST NET1, without connection cable (please order separately)									

¹ Specifications for black body radiator, T = 23 °C, t = 1 s. ² Noise equivalent temperature difference. ³ With dynamic adaption at low signal level. ⁴ Operating temperature up to 50 °C due to ^{ambience 95} the risk of burns.

AST A450C PL NV TL 55

Ratio pyrometer for industrial application

Fixed optics

Measurement distance a [mm]	a = 250	a = 650	a = 2000	a = 4000		
Temperature range	Distance ratio	Target size M [mm]			Aperture Ø [mm]	
500 °C to 1200 °C	50 : 1	5.0	13	40	80	8.0
600 °C to 1400 °C	100 : 1	2.5	6.5	20	40	6.0
700 °C to 1800 °C	200 : 1	1.3	3.5	10	20	6.0
800 °C to 2500 °C	300 : 1	0.8	2.2	6.7	13	6.0
900 °C to 3000 °C	300 : 1	0.8	2.	6.7	13	6.0

Vario optics with motor focus (adjustable in 8 steps)

Measurement distance a [mm]	240	360	540	800	1200	1800	2500	4000		
Temperature range	Distance ratio	Target size M [mm]							Aperture Ø [mm]	
500 °C to 1200 °C	40 : 1	6.0	9.0	14	20 30		45	63	100	8.0
600 °C to 1400 °C	80 : 1	3.0	4.5	6.8	10	15	23	32	50	6.0
700 °C to 1800 °C	160 : 1	1.5	2.3	3.4	5.0	7.5	11	16	25	6.0
800 °C to 2500 °C	240 : 1	1.0	1.5	2.3	3.4	5.0	7.5	11	17	6.0
900 °C to 3000 °C	240 : 1	1.0	1.5	2.3	3.4	5.0	7.5	11	17	6.0

Technical data DSR 55NV with video camera

Video signal	Composite video signal approx. 1V _{ss} at 75 Ω (galvanically isolated, video signal can be deactivated via software)
Color norm	PAL (B), 50 Hz (optional color norm NTSC (M), 60 Hz)
Resolution	1/3 inch video chip 628 × 586 pixels (NTSC option: 510 × 496 pixels)
Exposure control	automatic
Visible field	approx. 8 % × 6 % of adjusted measurement distance (NTSC option: 6.5 % × 5 %)
Date/time	Real-time clock with minimum 3 days power reserve, adjustable via software
Durable image displays	Target mark in measurement spot size, measurement temperature, K factor
Optional image displays	Via software: serial number, device name or user-defined text (16 characters), date, time, temperature unit °C/°F, 12/24 hours display

The video image can be displayed via the additionally available TFT monitor.



Pyrometers with different aiming variants

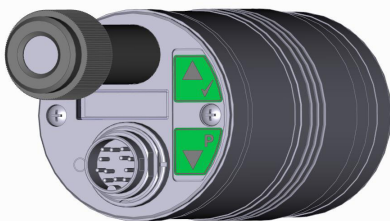

Through-lens sighting

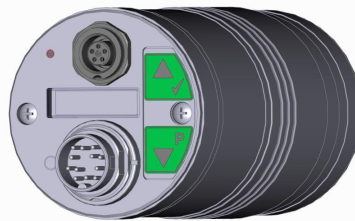

Video camera

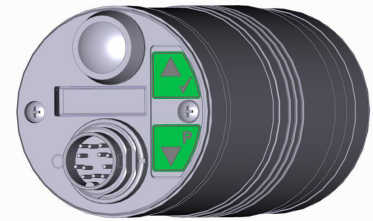

Laser aiming light







AST A450C PL NV TL 55

Ratio pyrometer for industrial application

Electrical, mechanical and optical accessories:			Part number	
Connection cable, straight plug, 12 pin	Connection cable, angulated plug, 12 pin	Length 2 m	3310A11111	3310A11131
		Length 5 m	3310A11112	3310A11132
		Length 10 m	3310A11113	3310A11133
		Length 15 m	3310A11114	3310A11134
		Length 20 m	3310A11115	3310A11135
		Length 25 m	3310A11116	3310A11136
		Length 30 m	3310A11117	3310A11137
		Video connection cable		Length 2 m
		Length 5 m	3310A16522	
		Length 10 m	3310A16523	
		Length 15 m	3310A16524	
		Length 20 m	3310A16525	
		Length 25 m	3310A16526	
		Length 30 m	3310A16527	
Mounting angle		adjustable	3310A21050	
Cooling jacket		including air purge unit, without mounting angle	3310A23050	
Ball flange		M40 × 1,5	3310A24020	
Air purge unit		stainless steel	3310A22050	
Power supply PSU 15		24 V DC, 0.6 A	3310A12010	
Threaded ring		with protection window quartz glass with protection window sapphire glass	3310A34022 3310A34052	
TFT monitor	TFT monitor industrial	3.5" with 2 m cable ¹	3310A16110	3310A16120
Adapter		Video/USB	3310A14030	
Handheld programming device DHP 1040		mobile handheld device for pyrometer parameterization	3310A17010	
Ethernet interface box DCU _{IO} ²		for integration into local networks and parameterization	3310A13500	

¹ More accessories on request. ² Cable length 5 m or 10 m available, too.

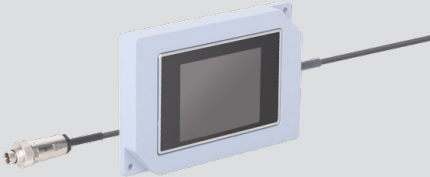
Selected accessories – Images

Mounting angle, adjustable	Cooling jacket	Air purge unit
Part number: 3310A21050 	Part number: 3310A23050 	Part number: 3310A22050 
TFT monitor industrial	Ball flange Part	Ethernet Interface-Box DCU _{IO}
Part number: 3310A16120 	number: 3310A24020 	Part number: 3310A13500 

Technical details are subject to change. 06.09.22

ISO 9001

Certified
Quality Management System

www.tuv-sud.com/ms-cert

Phone: +972 4 9990025
 sales@accuratesensors.com
 www.accuratesensors.com

Accurate Sensors Technology Ltd.
 Turag House Blue Street,
 Misgav Industrial Park Israel