

A250C PL/TL is a highly accurate digital two colour IR pyrometer from A series family for non contact temperature measurement. The Pyrometer measures the temperature of an object by calculating the ratio of the energies at two different wavelength bands. The ratio technique eliminates and reduces errors in temperature measurement caused by changes in Emissivity, Surface finish and energy absorbing materials such as Water vapour etc.

The two colour IR Pyrometer is used to measure the temperature in variety of applications in Forging, Annealing, Welding, Sintering Rolling mills, Cement, Glass, Crystal growing and many application where low temperature to be measured in ratio technique.



Technical Specifications

Model	A250C PL/TL
Temperature Range (Analog sub-range adjustable)	350°C....1000°C 450°C....1350°C
Spectral Range	1.5µm/1.6 µm
Photodetector Type	InGaAs/InGaAs
Distance to Spot Size Ratio	100:1 (350°C....1000°C) 200:1 (450°C....1350°C)
Emissivity (ε)	0.1....1.0 adjustable (Single color mode)
Emissivity Slope (ε1 / ε2)	0.75...1.25 slope adjustable (Two color mode)
Response Time	100 msec adjustable upto 10 sec
Accuracy	± 0.5% of the measured value + 1°C
Repeatability	0.1% of reading in °C + 1°C
Sighting Options	Laser Pilot Light(PL) / Through The Lens (TL)
Analog Output	0-20mA, 4-20mA, 0-10V (User selectable)
Digital Output	Bluetooth V2.0 RS-232/RS-485 (User selectable) *At a time only one digital output possible
Operating Temp. Range	0°C.....70°C 0°C.....200°C (With water cooling jacket)
Storage Temp. Range	-20°C...70°C
Adjustable Parameters and Features via Software	Emissivity, Emissivity Slope, Response Time, Clear Time(Peak Picker), Analog Output, Analog Scale(Sub range),Sensor type (Switches b/w 2-color or single color), Switch off level, Unit Of Temperature(°C/°F), Communication mode(Comm.mode), Record feature etc.
Power Supply	12V to 28V DC with reverse voltage protection
Power Consumption	Max 2.5 watt
Laser Power	<1 m watt
Protection Class	IP65
Housing	Stainless Steel
Isolation	Power supply,*Digital output and Analog output are galvanically isolated against each other
Operating Humidity	10-95%, Non-Condensing Conditions
Weight & Dimensions	600g Dia= Ø 49.5 mm; Length=118mm

Features

- Wide temperature ranges from 350°C to 1350°C.
- Spectral range 1.5µm/1.6 µm
- Two Color technique
- Laser targeting / Through the lens view finder sighting options
- Analog output options available like 0...20mA, 4...20mA and 0...10V
- Bluetooth V2.0 and RS-232/RS-485(user selectable) Serial interface
- User friendly PC software for communication

Standard Scope of Supply

- Pyrometer with Laser pilot light(PL)/Through the lens(TL) sighting(user can select while ordering)
- Analog output 4...20mA, 0..20mA, 0..10V
- Digital Interface RS-232 / RS-485(user selectable)
- Bluetooth V2.0
- 5 mtr long connection cable with connector
- 1.5 mtr. Communication Cable
- Calibration certificate, Software & Operation manual
- PC software "Infrasoft"

Optional

- Mechanical & Electrical Accessories
- Extra Cable Lengths

Applications

- Induction Heating
- Annealing
- Welding
- Forging
- Sintering
- Melting
- Rolling Mills
- Rolling Kilns
- Crystal growing
- Glass

Spot Sizes

Manufactured working distances WD (mm)	Spot Sizes (mm)	
	350° - 1000°C (FOV) 100:1	450° - 1350°C (FOV) 200:1
350	3.5	1.75
500	5	2.5
700	7	3.5
1000	10	5
1500	15	7.5
2000	20	10
2500	25	12.5
3000	30	15
5000	50	25
Infinite (∞)	8 (min.)	5 (min.)
Aperture (A)	7	4

Software

AST Infracoft

AST "Infracoft" software is under standard scope of supply. It offers possibilities of connecting three pyrometers simultaneously for parameter setting, view real time graph, offline graph and to evaluate measuring data. Communication between the pyrometer and the software is implemented via a cable connected between the pyrometer and the PC serial port. It comes with record feature, spot size calculator and parameter settings features.

Some of the parameters adjustable via software are

- Emissivity, Response Time,
- Clear Time (Peak Picker),
- Analog Output,
- Sub Range,
- Unit Of Temperature (°C/°F),
- Communication mode (Comm. mode).

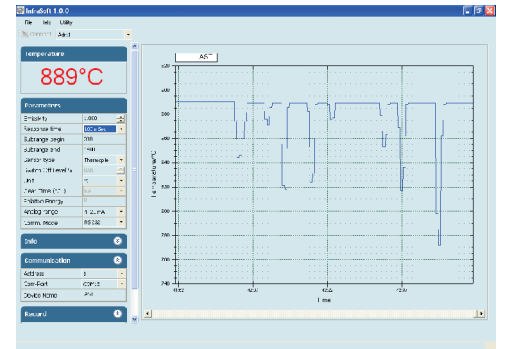

AST Infracmart

AST Infracmart is an android application used to communicate a pyrometer with mobile devices. This application works via bluetooth after pairing with mobile.

APK file for this android application will be provided with device.

Number of parameters set through the application are:

- Emissivity
- Response time
- Clear Time
- Unit of Temperature
- Analog Output
- Communication Mode
- Sensor Type
- Sub Range
- Data Logging



Pyrometer Drawing

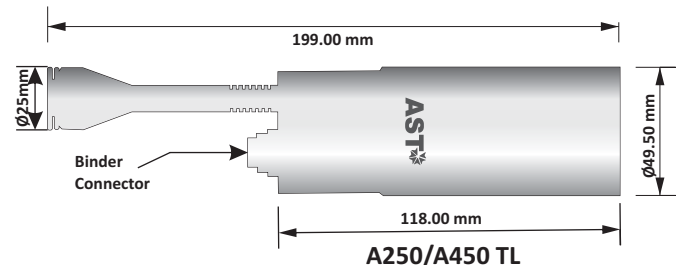
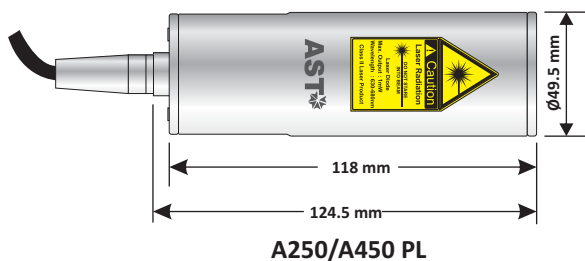

We measure accurate temperature in extreme conditions

Accessories

Water Cooling Jacket
(Reference no: 8000-08)



Adjustable Mounting Stand
(Reference no: 8000-07)

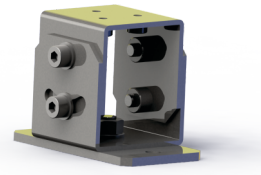

Air Purge Unit
(Reference no: 8000-04)



Adjustable Mounting Support
(Reference no: 8000-05)



Display & Parameterizer P-120
(Reference no: 9001-01)



Converter RS-232 ↔ RS-485
(Reference no: 9000-03)



Power supply Input 110/230V AC
Reference No. 9000 - 02
Output 24 V DC, 0.7Amp.



Temperature Indicator
(Reference no: 9000-01)



Pyrometer Accessories Drawings

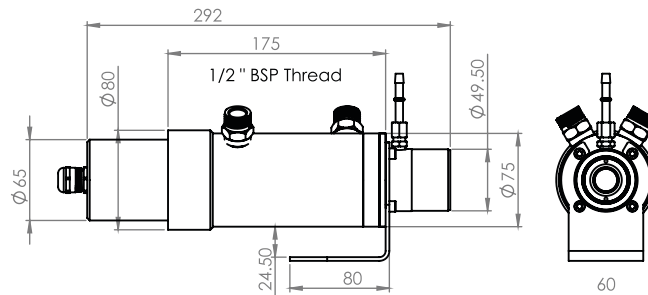

Water Cooling Jacket
(Reference no: 8000-08)

FOR 6 mm INSIDE
DIAMETER HOSE

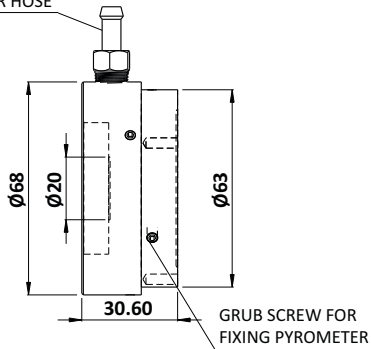

Air Purge Unit
(Reference no: 8000-04)

3 x M6 THRU AT 120°

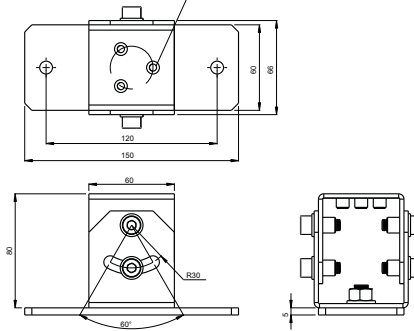

Adjustable mounting stand
(Reference no: 8000-07)

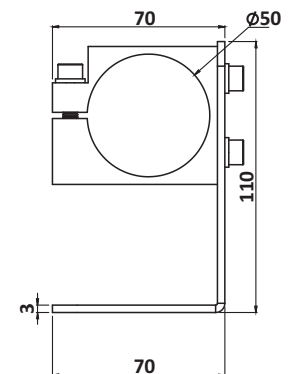

Mounting Clamp
(Reference no: 8000-05)

Accurate Sensors Technologies Pvt. Ltd.
Misgav Industrial Park, Misgav 20174 Israel
Phone :+972-4-9990025, Fax : +972-4-9990031
E-mail : info@accuratesensors.com

Accurate Sensing Technologies Pvt. Ltd.
188A, B-169 (Part), B-188 (A), Road No. - 5, M. I. A.,
Madri, Udaipur (Rajasthan) - 313003
Phone : +91-294-3507736, Fax : +91-294-3507731
Email : sales@accuratesensors.com

