

Highly Accurate On-Line Infrared Non-Contact Pyrometers for Special Applications of Ferrous and Non-Ferrous Metals as Stainless-Steel, Aluminium, Brass, Bronze, Copper.

A5-WL•
A5-WL-FO

A5-WL: 105 to 2500°C (221 to 4532°F)

A5-WL-FO: 350 to 1000°C (662 to 1382°F)



AST A5-WL is specially designed IR Pyrometers for non-contact temperature measurement in special applications.

AST A5-WL and AST A5-WL-FO are Multi-wavelength pyrometers use application specific data base derived from years of experience in real application. AST A5-WL and AST A5-WL-FO use special algorithms to accurately calculate both the actual temperature and emissivity of the surface .

AST A5-WL and AST A5-WL-FO have Laser Emission Immunity for $\lambda=910, 1032, 1064\text{nm}$ (Each $\lambda \leq 1080\text{nm}$) but not for keyhole welding mode.

They have a laser pointer which is aligned in line with the detector so that it ensures both laser and detector looks in to the same spot. This helps precise aiming even in long distances.

AST A5-WL and AST A5-WL-FO offer Bluetooth communication so that they can communicate with Android smart phones or laptop for viewing the measured temperature and for adjusting the parameters / selection of data base and data logging.

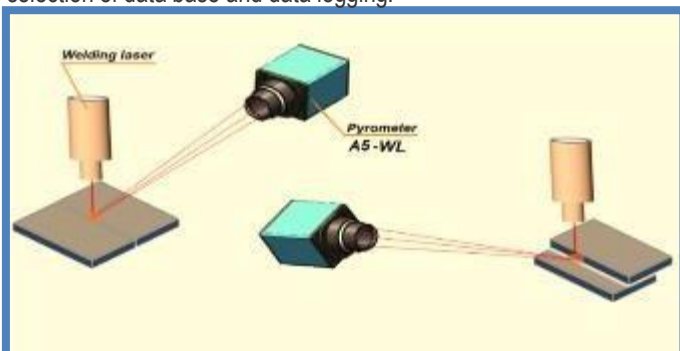

Features

- High accuracy - $0.25\% \pm 2^\circ\text{C}$ (3.6°F) of measured value for full range of emissivity.
- High consistency, suitable for closed loop control.
- Temperature ranges - see table at the beginning of the next page.
- Temperature range for measurement in front of black body, when measuring a shiny body minimum temperature will be higher.
- Fast response, compared to T/C.
- Full range of accessories and Wide range of built-in functions.
- Durability, low maintenance.
- Easy to install in existing line, replacing of contact probes.
- Capable of measuring targets with variable emissivity.
- Plug and play - No calibration required.
- AST NET sw software for PC
- AST Pyrometer Android Application via Bluetooth

Standard Scope of Supply

- Integrated laser pilot light
- Digital Interface RS-232
- Calibration Certificate, PC Software & Operation Manual

Optional

- Mechanical and Electrical Accessories
- Analog Output: 0...20mA or 4...20mA or 0-10V or K type T/C
- Extra Cable Lengths
- RS422, RS485, USB, Bluetooth

Applications

- Non-contact temperature measurements for special applications of Ferrous and Non-Ferrous Metals as Stainless-Steel, Aluminium, Brass, Bronze & Aluminium Welding

Technical Specifications

Specification	Model A5-WL	Model A5-WL-FO
Temperature Range (Analog sub-range adjustable)	105 - 900°C 200 - 1640°C 250 - 1850°C 360 - 2500°C	221- 1652°F 392 - 2984°F 482 - 3362°F 680 - 4532°F
Spectral Range	2.0...2.5 μm	
Photodetector Type	InGaAs Extended	
Distance to Spot Size Ratio	100:1 200:1	200:1
Emissivity	0.1 -1.0	
Response Time t90	Adjustable from 50 ms to 17 sec	
Accuracy and Repeatability	0.25% ± 2°C (3.6 °F) of measured value for full range of emissivity	
Sighting	Integrated Laser Pilot Light	
Power Supply	24VDC	
Analog Output	4-20 mA, 0-20 mA, 0-10V, K Type T/C	
Digital Output	RS-232, RS-422, RS-485, USB, Bluetooth	
Digital Display	P110	
Sensor overall dimensions	215 x 110 x 105 mm / 8.46 x 4.33 x 4.13 in	
Sensor weight	~2.0Kg / ~4.4lbs	
Operating temperature range	0 to +50°C / 32 to +122°F	
Storage temperature range	-20 to +70°C / -4 to +158°F	
Protection Class	IP65	

Spot Sizes

Measuring Distances [mm] / [in]	A5-WL Spot Sizes [mm] / [in]			
	FOV 1:100	FOV 1:200		
	105 - 900°C 221- 1652°F	200 - 1640°C 392 - 2984°F	250 - 1850°C 482 - 3362°F	360 - 2500°C 680 - 4532°F
500 / 20	5 / 0.2	2.5 / 0.1		
1000 / 40	10 / 0.4	5 / 0.2		
1500 / 60	15 / 0.6	7 / 0.3		
2000 / 80	20 / 0.8	10 / 0.4		
2500 / 100	25 / 1.0	12.5 / 0.5		
5000 / 200	50 / 2.0	25 / 1.0		

A5-WL-FO	
Measuring Distances [mm] / [in]	Spot Sizes [mm] / [in]
90 / 3.6	0.5 / 0.02
200 / 8	1 / 0.04
600 / 24	3 / 0.12
4500 / 180	23 / 0.9

We measure accurate temperature in extreme conditions

Pyrometer Drawing

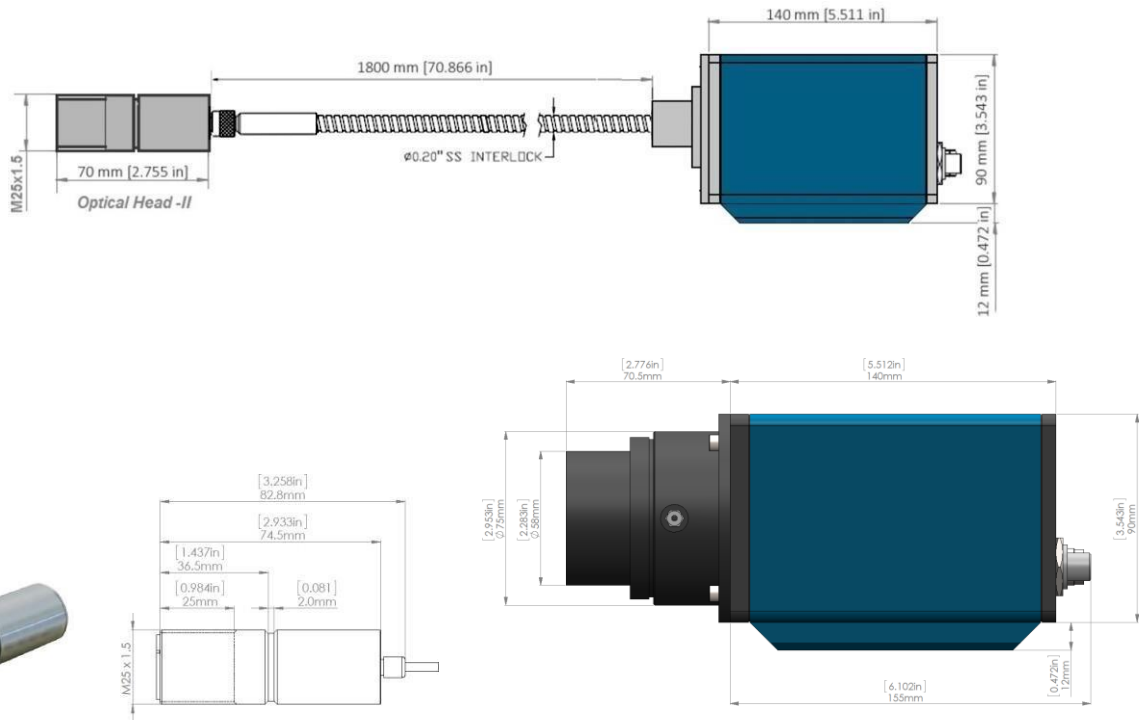

Accessories for A5-WL

AS3000 Application Selector
(Reference no: 300-07)



Power Supply Unit
(Reference no: 200-09)



Air Purge Tube 200 mm
(Reference no: 200-03)



Display & Parameterizer
(Reference no: P-110)



Adjustable Mounting
(Reference no: 200-01)



Air Purge Tube Adapter
(Reference no: 200-02)



Frontal Water-Cooling Plate
(Reference no: 200-06)



Top Water-Cooling Plate
(Reference no: 200-10)



We measure accurate temperature in extreme conditions

Accessories for A5-WL-FO

<p>Air purge unit for optical head II Reference No. 8200 - 01</p>	<p>Air purge unit for optical head-I Reference No. 8200 - 02</p>	<p>Adjustable Mounting for optical head II Reference No. 8200 - 03</p>	<p>Adjustable mounting for optical head-I Reference No. 8200 - 04</p>
			
<p>Single Channel Display P110</p>	<p>Power supply Input 110/230V AC Reference No. 9000 - 02 Output 24 V DC, 0.75Amp</p>	<p>Temperature Indicator with retransmission output 4..20mA Reference No. 9000 - 01</p>	<p>Converter RS-485 ↔ RS-232 Reference No. 9000-03</p>
			

AST 
Accurate Sensors Technologies

Misgav Industrial Park, Misgav 2017400 Israel
Ph.: +972-4-9990025, Fax: +972-4-9990031
E-mail: info@accuratesensors.com
www.accuratesensors.com



We measure accurate temperature in extreme conditions